



SINCE 1976,

INNOVATING TO MAKE FORMWORKERS LIVES EASIER

Panels | Ties | Corners | Cages | Accessories

192, 6 rang,
St-Rosaire (QC) G0Z 1K0

www.t4s2009.com
Phone: 819 758-1155 | 1 800 567-2518

OUR FOUNDATION



Established in 1976 by Jean-Guy Bergeron, **4 Seasons Ties** is now a third generation, family owned Canadian company. With over 40 years of experience, 4 Seasons Ties has grown to be the leading manufacturer of formwork products in North America. We are dedicated to creating innovative products and solutions to facilitate and simplify the installation of quality formwork.

It all started in 1976 when Jean-Guy was having difficulty obtaining form ties so he decided to buy a press machine and started manufacturing his own ties. Jean-Guy quickly improved the tie by adding a special "V" near both ends of the tie so it would hold better in the concrete. This feature made his tie very popular and he established a very strong market with the local formwork companies. With Jean-Guy's excellent customer service, dedication and perseverance he expanded his sales territory and invested in new machines capable of mass producing of quality plywood formwork panels. This market led to the development of new formwork products such as many different corner styles, cages, tools and accessories.

Jean-Guy Bergeron passed away in 2017, and under the ownership of his daughter, son and son-in-law as general manager, the company continues to thrive and grow. **4 Seasons Ties 2009** now extends from coast to coast in Canada and United States.

"Pioneers and always at the forefront of our field, our mission at **4 Seasons Ties 2009** is to make formworkers and contractors lives easier by manufacturing and distributing formwork material that meets their needs. In doing so, we are continually committed to the highest standards of performance, quality and market sustainability."



TABLE OF CONTENTS

<u>TIES</u>	<u>4</u>
<u>CAGES</u>	<u>5</u>
<u>CORNERS</u>	<u>8</u>
<u>PANELS</u>	<u>10</u>
<u>COLUMN PANELS</u>	<u>14</u>
<u>SCAFFOLDING BRACKETS</u>	<u>17</u>
<u>STEEL SCAFFOLDING BRACKETS</u>	<u>19</u>
<u>ACCESSORIES</u>	<u>20</u>
<u>OIL SPRAYER AND PARTS</u>	<u>30</u>
<u>PARTNERS</u>	<u>32</u>

TIES

REGULAR

REGULAR TIES

010-0000XX

We offer an extensive inventory of ties from 4" to 96".

4" to 19" ties in boxes of 250;
20" to 24" ties in boxes of 200;
25" to 96" ties in bundles of 50.

Option: custom size,
metric size,
stainless steel



"V" SHAPE

"V" SHAPED TIES

010-0000XX-V

Designed to hold a corner firmly in place, by hooking onto another tie when you have an offset.

Option:
Fit with 3x3 or 4x4 corners,
Stainless steel

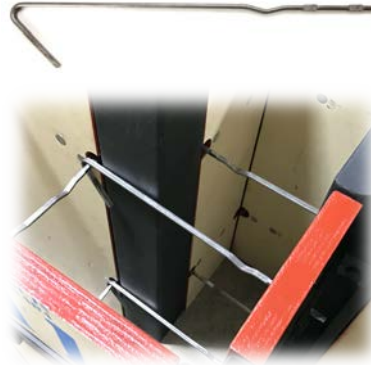

STYROFOAM

STYROFOAM TIES

013-X000XX

These ties are used to hold insulating panels in place when pouring the concrete. The steel plates slide into notches which can be customized upon request.

Option: Welded plates

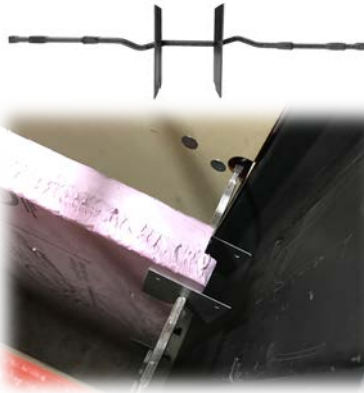

WITH WATER SEAL

WATER SEAL

012-X900XX

The water seal can be added to any tie as an option.



WITH CONES

CONE TIES

012-0000XX

The cones can be added to any tie as an option.

Designed to provide a nice finish.
Available with 1 or 2 cones.

Regular: **A** = 1/2" **B** = 1" **C** = 1"
Large: **A** = 5/8" **B** = 1 1/2" **C** = 1 3/8"

Inside wall breaking distance:
3/4" (small)
1 3/8" (large)

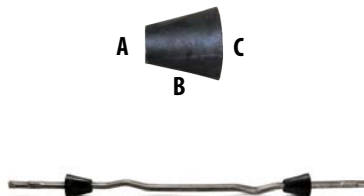

RESICOIL

RESICOIL

395-TMA006

These ties are made for one side forming. To be used with a 1/2" coil rod.

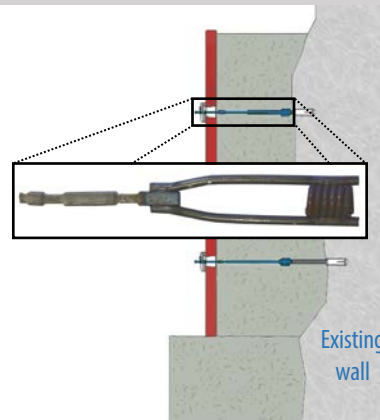

CAGES

ALL OUR CAGES ARE CERTIFIED



PANEL CAGE

081-XX0X00

A single crane operator can place the panels exactly where they are needed on the jobsite. Cages help prevent panels from being damaged and will simplify the job for your employees.

We also manufacture custom cages according to customer specifications.

Option: Folding Top
Capacity: 20-22 panels
Ideal capacity: 21 panels

PANEL



176 lb. (8'42")

PANEL



246 lb. (8'42")

2 TIER MOVABLE STACKER CAGE FOR PANELS

081-XX0X20

Designed to take 4' 3" panels or less (40 to 44 panels per cage). Once the top empty, shelf can be tilted back for easier access.

Option: Folding Top
Capacity: 40-44 panels
Ideal capacity: 42 panels

STACKABLE PANEL CAGE

081-XX0X00-H

To comply with height restrictions, the horizontal panel cage can be transported laying down and stood upright on the jobsite.

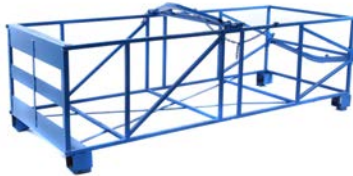

PANEL

PANEL



246 lb. (8'42")

2 TIER FIXED STACKER CAGE FOR PANELS

081-XX0X10

Designed to take 4' panels or less (40 to 44 panels per cage).

Option : Folding Top, Filler Cage,

LUMBER CAGE

085-XX0200-H

Designed to store lumber. The inside can be customized upon request.



LUMBER

TAKE CARE TO WATCH YOUR TOTAL HEIGHT



Our cages are made for easier handling and extending the life of the forms. Available in 42" and 39". We also manufacture custom size cages upon request.

CAGES

ALL OUR CAGES ARE CERTIFIED



FILLER

CORNER

FILLER CAGE

082-XX0200

Designed to store fillers and facilitate their retrieval. Sections can be divided as needed.

Option: Folding Top

Utility: Filler panels 4" to 16"
Capacity: 13 fillers per division



240 lb. (8'42")



244 lb. (8'42")

CORNER CAGE

083-XX0200

Designed for storing corners and making retrieval easier. A single crane operator can place the corners exactly where they are needed on the jobsite.

(corners not included)

Option: Folding Top

Please note that the divisions can be made in various widths to optimize space for different fillers sizes.

The interior clearance available of the cage is 40".

Standard divisions: 10", 12", 16"
6", 7", 8", 16"

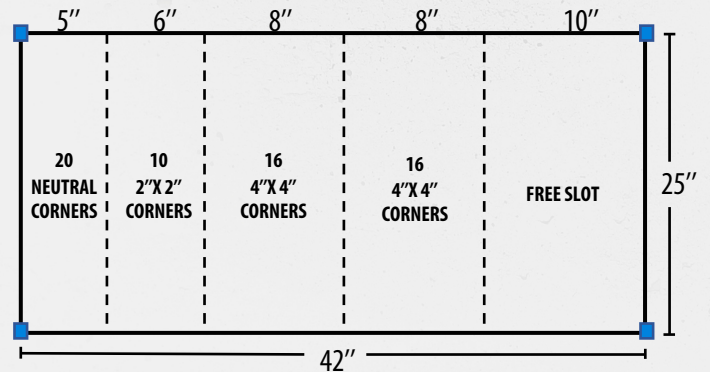

PANEL

FILLER

FOLDING TOP PANEL CAGE

081-XX0201

When the top is folded, it is 2" higher than the height of the panel to make transportation easier.

The interior clearance available of the cage is 38".

Option: Fixed top



185 lb. (8'42")



245 lb. (8'42")

FOLDING TOP FILLER CAGE

082-XX0201

When the top is folded, it is 2" higher than the height of the panel to make transportation easier.

The interior clearance available of the cage is 38".

Option: Fixed Top

Our cages are made for easier handling and extending the life of the forms. We also manufacture custom size cages upon request.

CAGES

ALL OUR CAGES ARE CERTIFIED



PANEL

ACCESSORY

3 TIER STACKER CAGE FOR PANELS

081-XX0250

Designed to take 2'8" panels or less (total of 60 to 66 panels per cage). The upper and middle tiers can be tilted.

Option : Folding Top, Filler Cage



336 lb. (8'42")

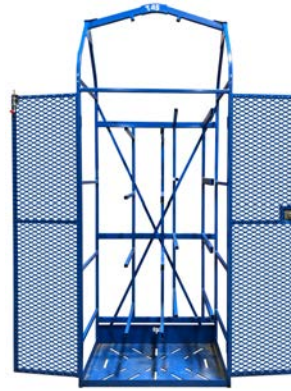

171 lb. (8'42")

SCAFFOLDING BRACKETS CAGE

084-80M200A

Designed to store scaffolding brackets.

ACCESSORY

ACCESSORY

TOOL AND 20" MONOPIECE ALUMINUM SCAFFOLDING BRACKETS

084-T80M200

Designed to store tools and aluminum scaffolding brackets.

Model 092-C20100 see in « aluminum scaffolding brackets » section.



610 lb. (8'42")



WORKERS CAGE

084-TT0000

Certified cage to carry workers on a job site.

ACCESSORY

ACCESSORY

TOOL CAGE

084-TXXX200

Designed to store tools. The shelves can be customize upon request.



180 lb. (36" x 14")



SMALL ACCESSORY CAGE

084-300200

Designed for storing your small tools and accessories.

Dimensions available:

Total height: 3' with a 36" x 14" bottom or 4' and more with a 42" x 26" bottom.

Our cages are made for easier handling and extending the life of the forms.
We also manufacture custom size cages upon request.

CORNERS

3X3 CORNER

07X-XX003X

This corner minimizes the need to use odd fillers. It now comes with latches.



8'-4B:	31.3 lb.	8'6"-5B:	34.4 lb.	9'4"-7B:	40 lb.
8'-6B:	34.3 lb.	8'6"-6B:	35.9 lb.	9'11"-7B:	41.8 lb.

INSIDE

INSIDE

4X4 CORNER (45°) FIXED

07X-XX017X

This fixed corner locks the panels in place to obtain a 45° angle. It can be used with our 2"x2" 135° outside corner and also with our 135° outside corners for 8" and 10" wall thicknesses or with the 45° bracket.

Custom sizes are also available on request.



8'-4B:	41.6 lb.	8'6"-5B:	45.4 lb.	9'4"-7B:	52.3 lb.
8'-6B:	45 lb.	8'6"-6B:	47 lb.	9'11"-7B:	54.8 lb.

4X4 CORNER

07X-XX004X

This corner delivers superior performance. It is designed with a fold that makes it more durable.

Option : 5" x 5"
6" x 6"



8'-4B:	42.5 lb.	8'6"-5B:	46.3 lb.	9'4"-7B:	53 lb.
8'-6B:	45.4 lb.	8'6"-6B:	47.7 lb.	9'11"-7B:	55.7 lb.

INSIDE

INSIDE

4X6 CORNER

07X-XXX10X

The 4"x6" corner is used when the thickness of the adjacent wall is different.

Option : Reversible 07X-XX009X



8'-4B:	54.4 lb.	8'6"-5B:	60.7 lb.	9'4"-7B:	72.5 lb.
8'-6B:	62.1 lb.	8'6"-6B:	64.5 lb.	9'11"-7B:	75.3 lb.

4X4 SWING CORNER

07X-XX021X

This corner is designed for multi angle corners.

Option : 6" x 6"
8" x 8"



8'-4B:	48.9 lb.	8'6"-5B:	53.1 lb.	9'4"-7B:	60.5 lb.
8'-6B:	51.8 lb.	8'6"-6B:	54.5 lb.	9'11"-7B:	63.6 lb.

INSIDE

INSIDE / OUTSIDE

2" OFFSET CORNER

07X-XXX16X

The 2" offset corner is used in the middle of a straight wall to go from an 8" wall to a 10" wall and vice-versa.

Option : Custom size available
Reversible 07X-XX015X



8'-4B:	47.5 lb.	8'6"-5B:	52.7 lb.	9'4"-7B:	62.2 lb.
8'-6B:	53.4 lb.	8'6"-6B:	55.6 lb.	9'11"-7B:	64.9 lb.

Our corners are made with top quality materials and will fit your panels perfectly. We also manufacture custom size corners on request.

CORNERS

NEUTRAL CORNER

07X-XX001X

This corner does not affect the size of the filler you need.



8'-4B:	17.7 lb.	8'6"-5B:	19.9 lb.	9'4"-7B:	24 lb.
8'-6B:	20.6 lb.	8'6"-6B:	21.3 lb.	9'11"-7B:	24.9 lb.

OUTSIDE



8'-4B:	18.8 lb.	8'6"-5B:	21.1 lb.	9'4"-7B:	25.4 lb.
8'-6B:	21.8 lb.	8'6"-6B:	22.6 lb.	9'11"-7B:	26.3 lb.

1X1 CORNER

07X-XX007X

This corner minimizes the use of odd fillers.

OUTSIDE



8'-4B:	25.5 lb.	8'6"-5B:	28.2 lb.	9'4"-7B:	33.2 lb.
8'-6B:	28.4 lb.	8'6"-6B:	29.7 lb.	9'11"-7B:	34.6 lb.

OUTSIDE



8'-4B:	25.5 lb.	8'6"-5B:	28.2 lb.	9'4"-7B:	33.2 lb.
8'-6B:	28.4 lb.	8'6"-6B:	29.7 lb.	9'11"-7B:	34.6 lb.

2X2 CORNER

07X-XX002X

This corner allows you to use a wide range of fillers. Also available in 3"x3".

Option : Chamfer corner

2X2 CORNER (135°)

07X-XX024X

This corner is to be used with our 45° inside corner.

OUTSIDE

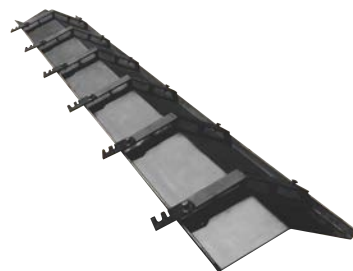

8'-4B:	60.5 lb.	8'6"-5B:	65.4 lb.	9'4"-7B:	74 lb.
8'-6B:	63.4 lb.	8'6"-6B:	66.9 lb.	9'11"-7B:	78 lb.

OUTSIDE



8'-4B:	35.6 lb.	8'6"-5B:	38.9 lb.	9'4"-7B:	44.9 lb.
8'-6B:	38.5 lb.	8'6"-6B:	40.4 lb.	9'11"-7B:	47.1 lb.

135° CORNER

8" **07X-XXX18X**

10" **07X-XXX19X**

This outside corner eliminates the need for fillers, saving you time and money. It is to be used with our 45° inside corner. Standard sizes offered for 8" and 10" wall thicknesses.

SWING CORNER 2X2

070-SPECIAL

This corner is designed for multi angle corners. To be use on the outer side instead of a multi angle lock.

Our corners are made with top quality materials and will fit your panels perfectly. We also manufacture custom size corners on request.

PANELS

TOP STACKING SYSTEM

STAGGER STACKING SYSTEM (OR HIGH AND LOW SYSTEM)

This system works with 8' 6 bars and 8' 6" 6 bars family of panels.

Stacking angle bar
See page 25

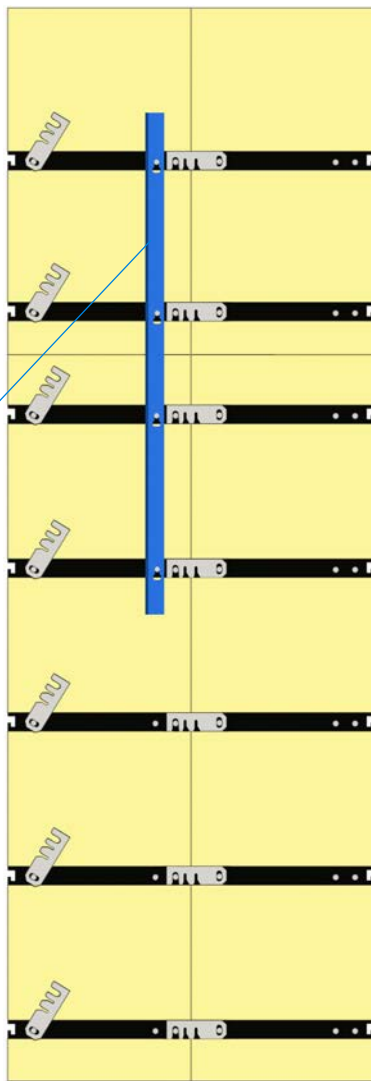

PANELS

8' - 4 BARS

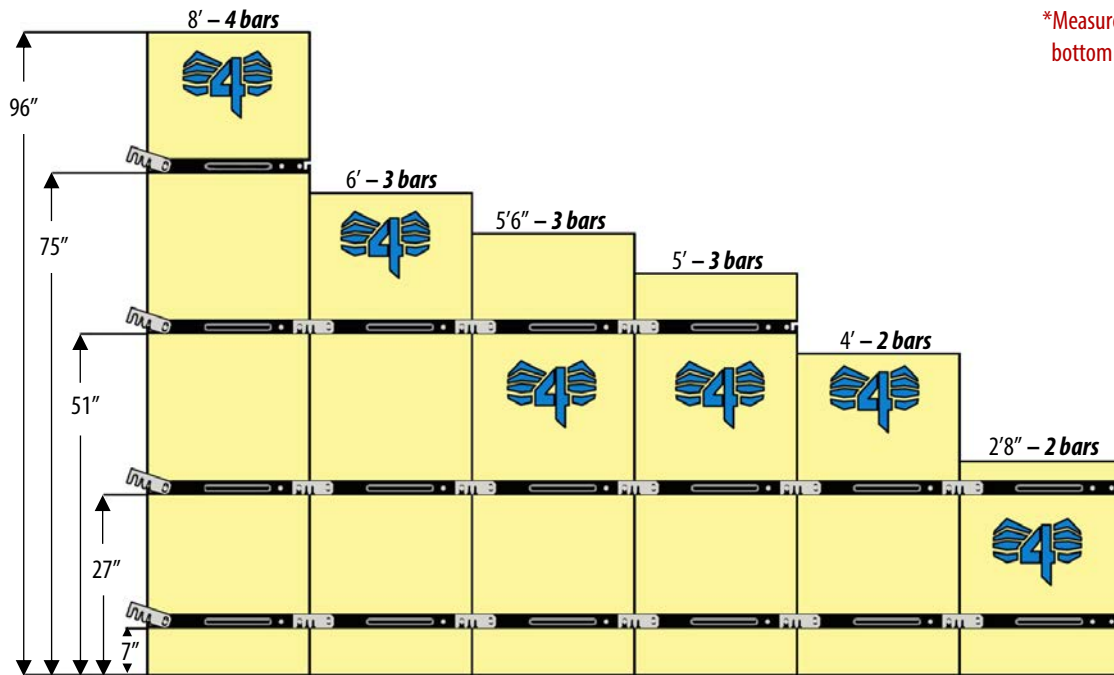

*Measurements are from the bottom of the panels to the bottom of the bars.

8' - 5 BARS - US

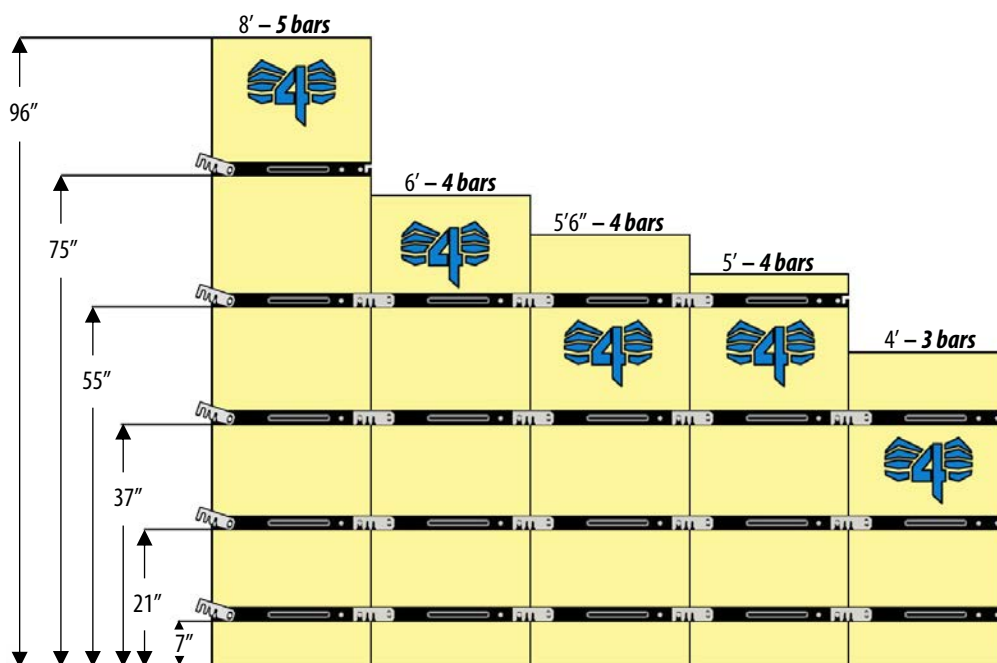

PANELS

8'6" – 5 BARS – CANADIAN

*Measurements are from the bottom of the panels to the bottom of the bars.

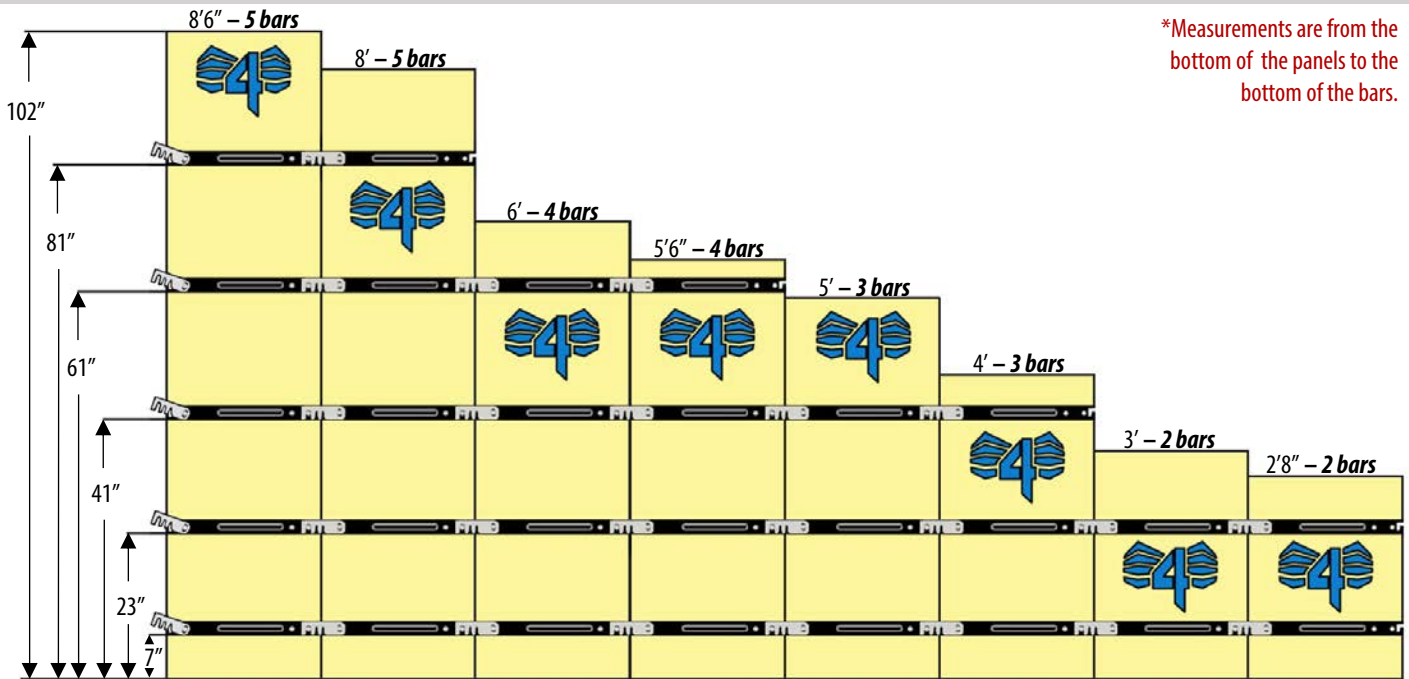

8'6" – 5 BARS – 4 SEASONS

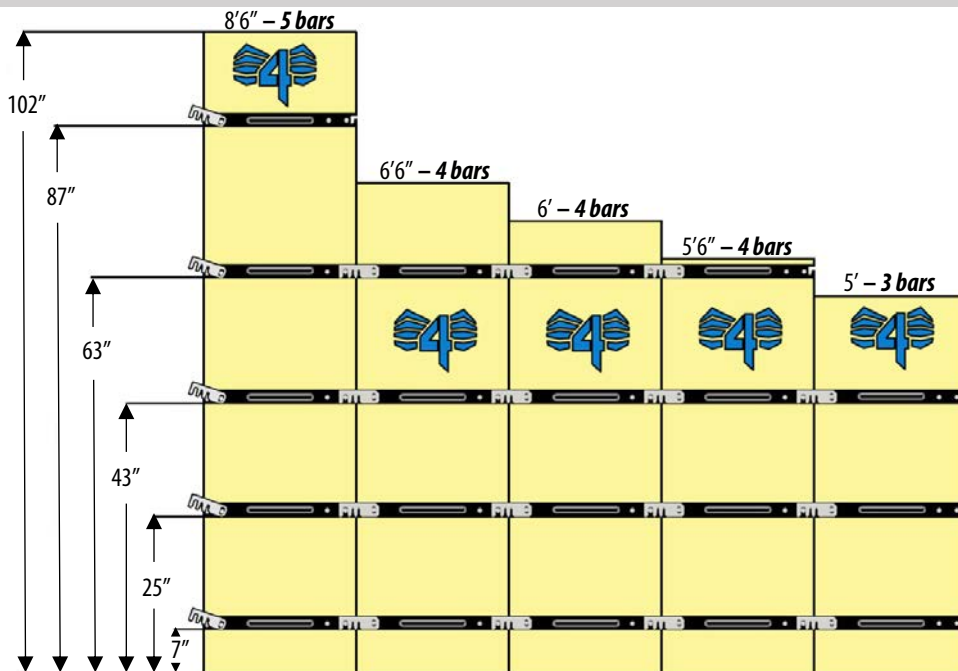

PANELS

9'4" – 7 BARS

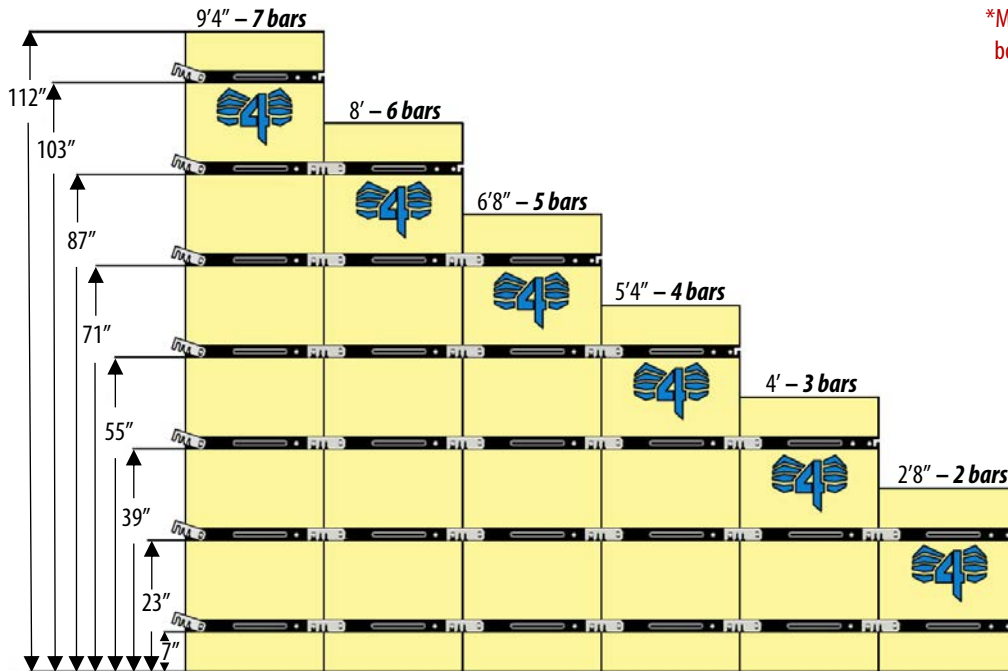

*Measurements are from the bottom of the panels to the bottom of the bars.

9'11" – 7 BARS

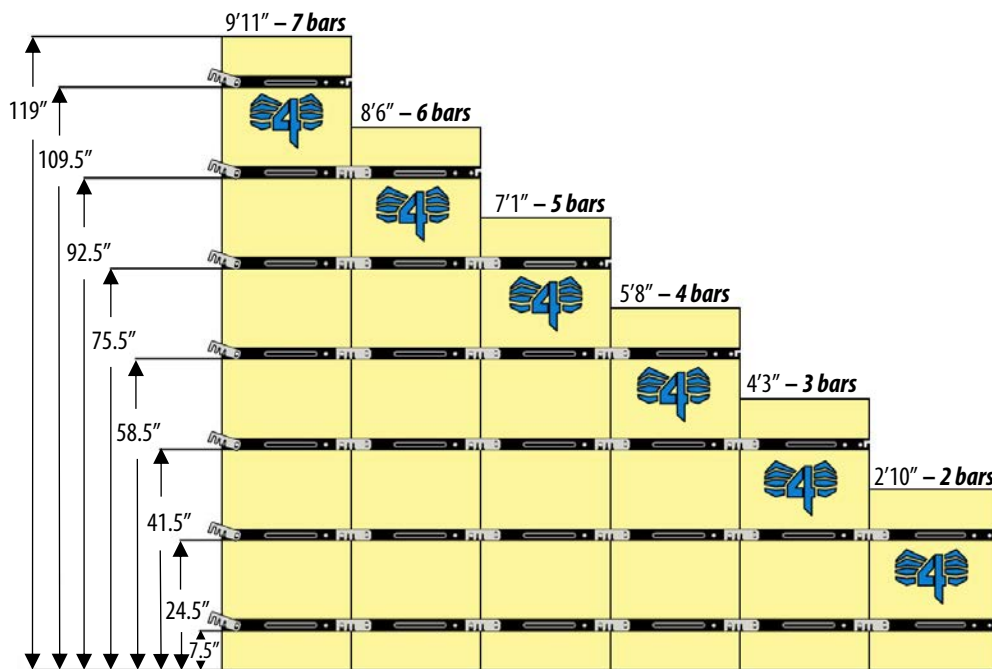

COLUMN PANELS

SYSTEM 1

The main advantage of this system is that no accessories are required for assembly. The system is simple and is quick to assemble. Ideal for small columns.



SYSTEM 2

This galvanized angle bar column is highly resistant to pressure during the casting process. Indeed, the angle bar being 3" wide reduces the risk of bending. Since this system is in kit form, the plywood can be turned around when it becomes worn. This feature doubles the life of the panel.



- Stronger
- Can build higher
- Many options of dimensions

LAMINATED BAR

832-XX00XX

This accessory provides reinforcement when assembling columns of 10' or more. It is easy to use and doesn't require any tools when pairing up two panels.

* Please note that you must state that you intend to reinforce the panel when placing your order.

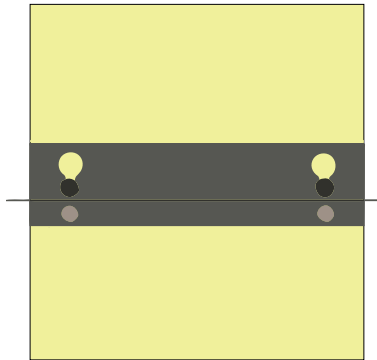

ANGLE BAR FOR SYSTEM 2

834-012024

12" to 24"

834-024036

24" to 36"

This angle bar is available in two different lengths. One extends from 12" to 24" and the other from 24" to 36". These measurements are calculated in multiples of 2".



We also offer custom-cut measurements

COLUMN PANELS

LOCATIONS OF BARS FOR OUR DIFFERENT COLUMN PANEL SYSTEMS

COLUMN PANEL

Upon request, the panels or column fillers can be cut to the desired height. However, the distance between bars remains the same on the panel, as shown on the picture opposite, whether it's the two latch bars or the round rods. Maximum height is 10'.

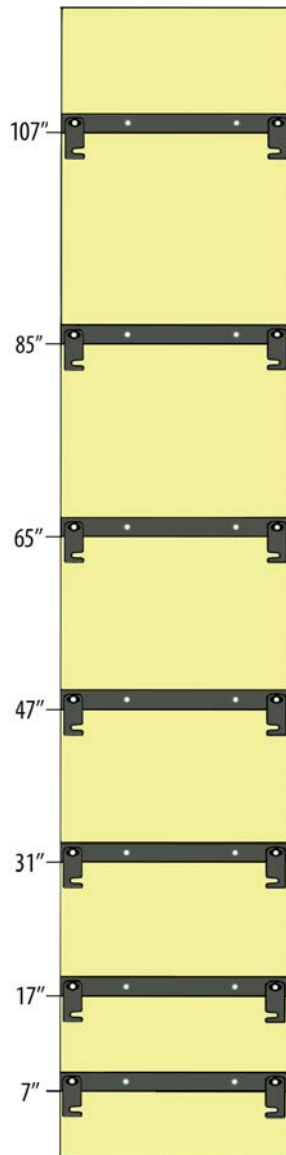

*This panel is compatible with system 1 only

COLUMN FILLER

This panel with round rods is compatible with both column systems. It is available in 7 sizes, each with a 3" variation in width thanks to the notches at each end of the round rod. The choices are:

Width of filler	Lengths available
12" 3/8	10"-11"-12"
14" 3/8	12"-13"-14"
16" 3/8	14"-15"-16"
18" 3/8	16"-17"-18"
20" 3/8	18"-19"-20"
22" 3/8	20"-21"-22"
24" 3/8	22"-23"-24"

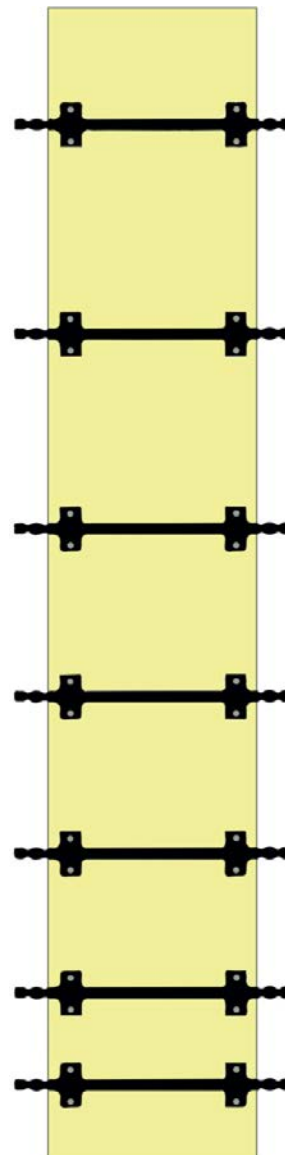

*This filler is compatible with both systems

We also offer custom-cut measurements

STEEL FILLERS

EXPANDABLE STEEL FILLER

05X-XX099X

This expandable panel makes it easier to laterally adjust formwork by allowing different widths. Expandable from 6" to 9".

SPECIAL



SPECIAL



STEEL FILLER

05X-XX00XX

Steel fillers are stronger than wood and a definite asset to your forming system. They are available in 4" to 8" widths.

6" to 8" fillers have tie slots.

SCAFFOLDING BRACKETS

All our scaffolding brackets are approved

LIGHT ALUMINUM 20"

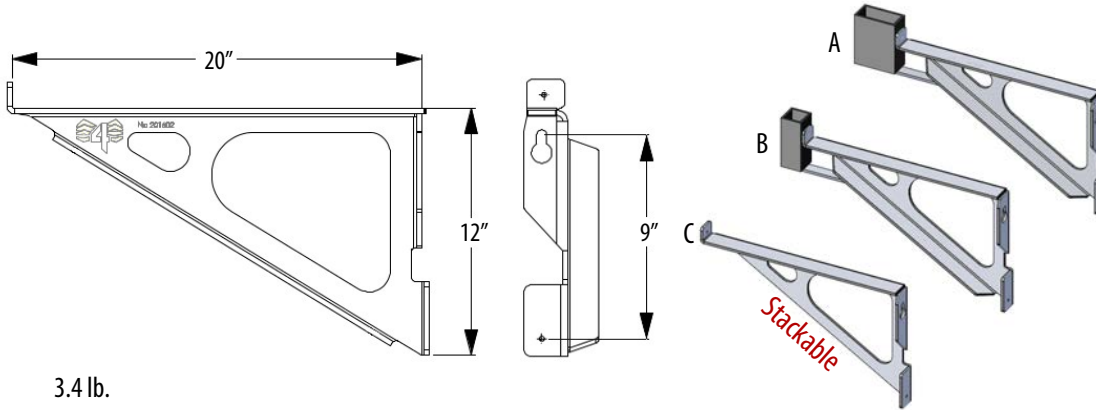

3.4 lb.

A : 092-C20104

B : 092-C20102

C : 092-C20100

This 20" scaffolding bracket fits on any panel. The top is attached to a bolt on the panel and the bottom can be fixed with a nail. It is offered with a pocket to install a guard rail, see the options below.

Specifications available on request.

Option : 2"x 4" Pocket(A) **Not stackable**
2"x 2" Pocket (B) **Not Stackable**

ALUMINUM OR STEEL 20"

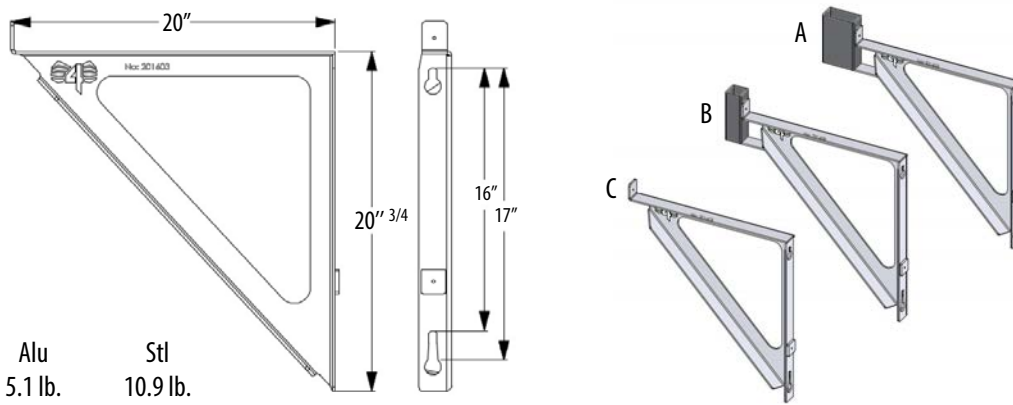

Alu
5.1 lb.

Stl
10.9 lb.

Aluminum

Steel

A : 092-C20224

A : 094-C20224

B : 092-C20222

B : 094-C20222

C : 092-C20220

C : 094-C20220

This 20" scaffolding bracket model is available in **Aluminum** or in **Steel**. It fits on any panel. It offers 2 attaching systems. It can be attached to 2 bolts or, 1 bolt with a nail fixed to the bottom. It is offered with a pocket to install a guard rail, see the options below.

Option : **Aluminum** or **Steel**
2"x 4" Pocket(A)
2"x 2" Pocket (B)

ALUMINUM 20" FITS ON 4 DIFFERENT BOLT SPACINGS

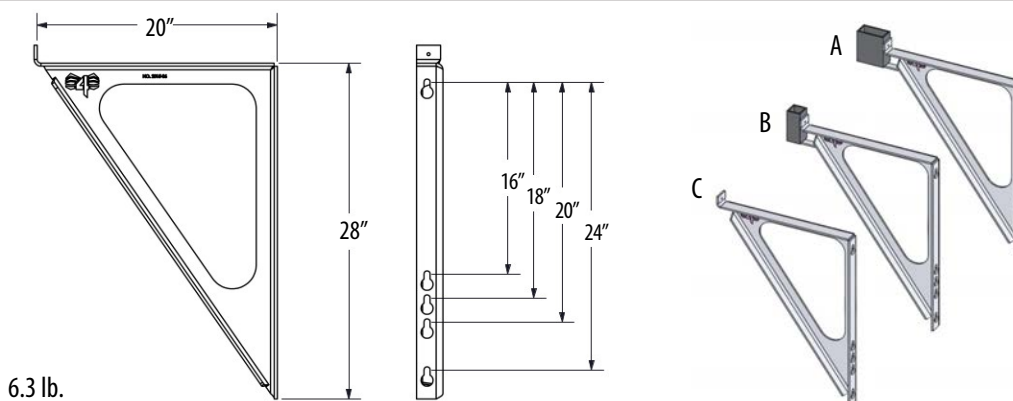

6.3 lb.

A : 092-C20244

B : 092-C20242

C : 092-C20240

This universal 20" scaffolding bracket can fit on 4 different bolt spacings as shown in the middle view. It attaches on 2 bolts on panel bars. It is offered with a pocket to install a guard rail, see the options below.

Option : 2"x 4" Pocket (A)
2"x 2" Pocket (B)

SCAFFOLDING BRACKETS

All our scaffolding brackets are approved

LIGHT ALUMINUM OR STEEL 24"

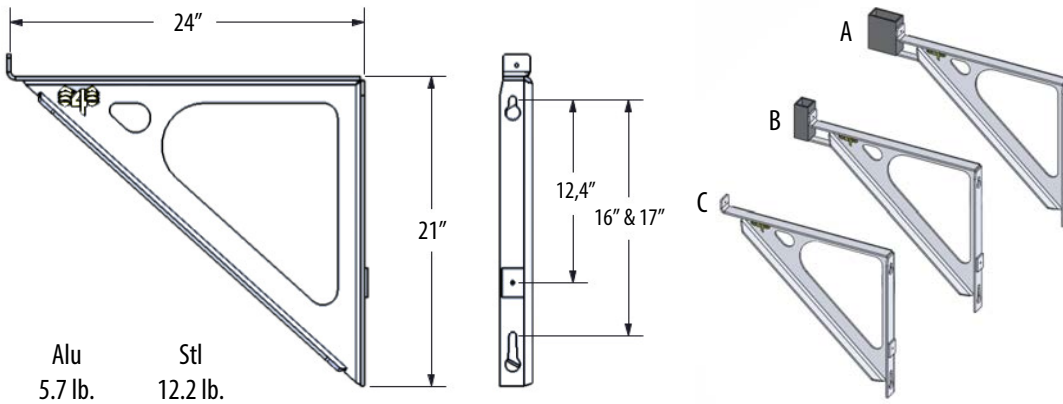

Alu 5.7 lb.
Stl 12.2 lb.

Aluminum	Steel
A : 092-C24224	A : 094-C24224
B : 092-C24222	B : 094-C24222
C : 092-C24220	C : 094-C24220

This 24" **Aluminum** or **Steel** scaffolding bracket fits on any panel. It offers 2 attaching systems. It can be attached to 2 bolts or 1 bolt with a nail fixed to the bottom. It is offered with a pocket to install a guard rail, see the options below.

Specifications available on request.

Option : **Aluminum** or **Steel**

2"x 4" Pocket(A) 2"x 2" Pocket (B)

ALUMINUM 24" FITS ON 4 DIFFERENT BOLT SPACINGS

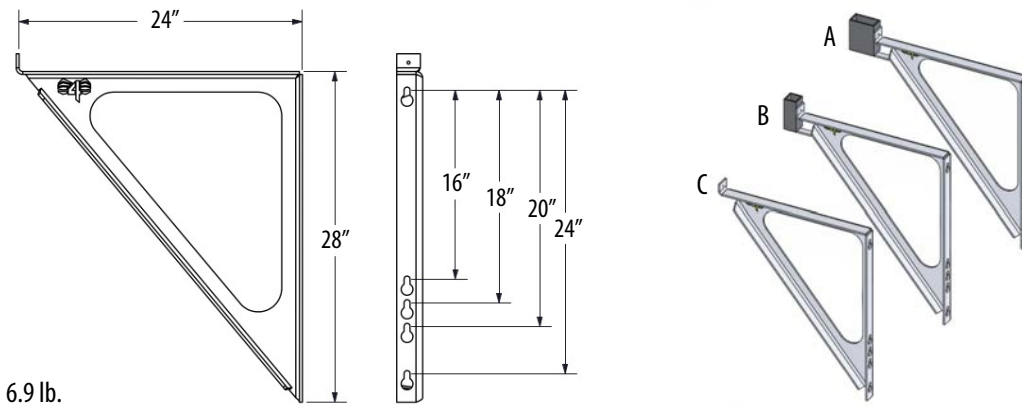

6.9 lb.

A : 092-C24244
B : 092-C24242
C : 092-C24240

This universal 24" scaffolding bracket can fit on 4 different bolt spacings as shown in the middle view. It attaches on 2 bolts on panel bars. It is offered with a pocket to install a guard rail, see the options below.

Option : 2"x 4" Pocket (A)

2"x 2" Pocket (B)

ALUMINUM OR STEEL 30"

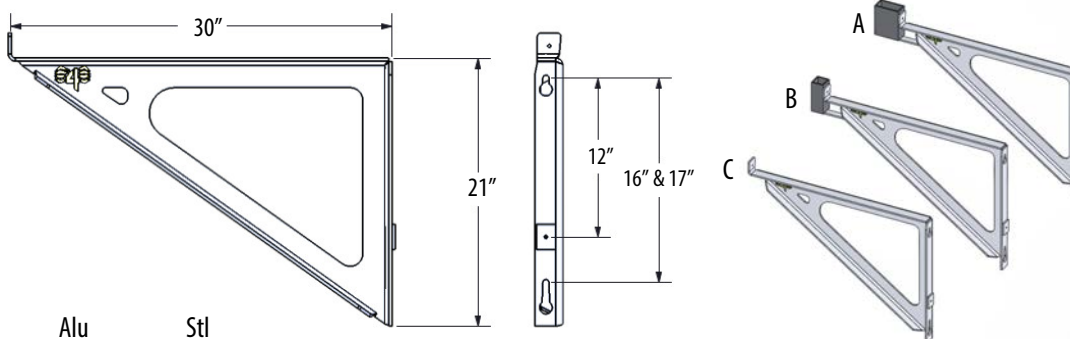

Alu 7.4 lb.
Stl 15.5 lb.

Aluminum	Steel
A : 092-C30224	A : 094-C30224
B : 092-C30222	B : 094-C30222
C : 092-C30220	C : 094-C30220

This 30" **Aluminum** or **Steel** scaffolding bracket fits on any panel. It offers 2 attaching systems. It can be attached to 2 bolts or 1 bolt with a nail fixed to the bottom. It is offered with a pocket to install a guard rail, see the options below.

Option : **Aluminum** or **Steel**

2"x 4" Pocket (A) 2"x 2" Pocket (B)

STEEL SCAFFOLDING BRACKETS

All our scaffolding brackets are approved

LIGHT STEEL 20"

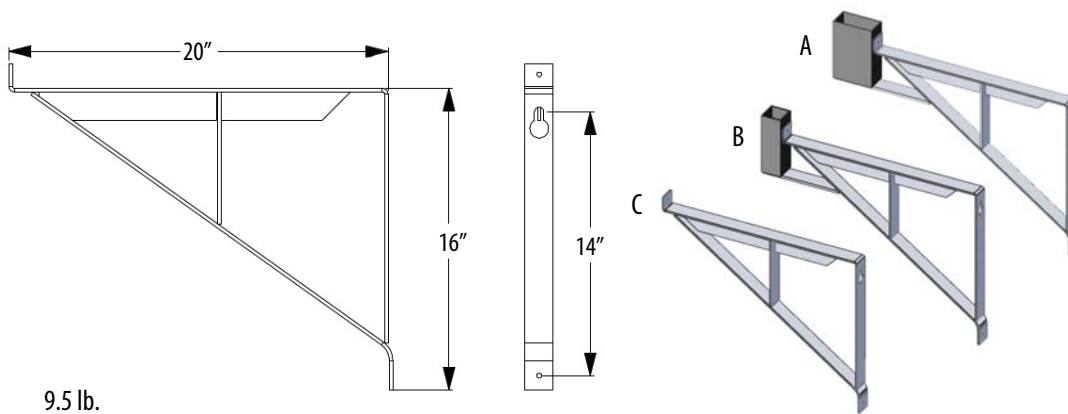

9.5 lb.

A : 094-CL2014

B : 094-CL2012

C : 094-CL2010

This 20" scaffolding bracket fits on any panel. The top is attached to a bolt on the panel and the bottom can be fixed with a nail. It is offered with a pocket to install a guard rail, see the options below.

Specifications available on request.

Option : 2"x 4" Pocket (A)
2"x 2" Pocket (B)

STEEL 24" FITS ON 5 DIFFERENT BOLT SPACINGS

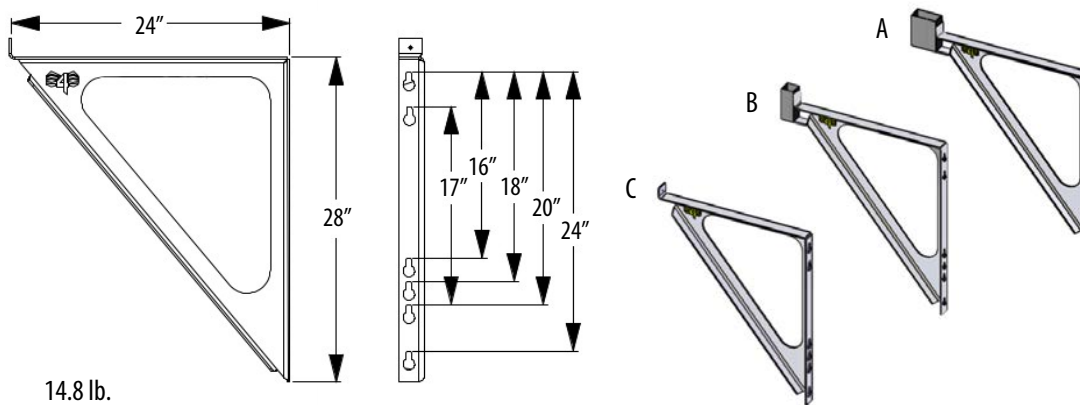

14.8 lb.

A : 094-C24254

B : 094-C24252

C : 094-C24250

This universal 24" scaffolding bracket can fit on 5 different bolt spacings as shown in the middle view. It attaches on 2 bolts on panel bars. It is offered with a pocket to install a guard rail, see the options below.

Option : 2"x 4" Pocket (A)
2"x 2" Pocket (B)



ALUMINUM SAFETY RAILING POST

092-GC0022

This 2"x 2" aluminum post sits in an aluminum scaffolding bracket creating a guard rail for work at heights. Designed in compliance with the Building Code.

* Scaffolding bracket sold separately

ACCESSORIES

ALUMINUM WALER BRACKET

10" **091-C0010A**

12" **091-C0012A**

This bracket is designed to be used as a shelf to support tools or any other materials. The top is attached to a bolt on the panel and the bottom can be fixed with a nail.

**Not for scaffolding*

1.46 lb.

TIME SAVERS



TIME SAVERS



3.46 lb. (8")

STEEL WALER BRACKET

091-CR000XX

The top is attached to a bolt on the panel.

Options: 6", 8", 10" or 12"

**Not for scaffolding*

EXTERIOR ROUND WALL BRACKET

091-BA4001

This bracket is designed to attach 2 outside panels at variable angles. You set the desired angle to form a round outside wall.



0.46 lb.



TIME SAVERS



0.46 lb.



TIME SAVERS

INTERIOR ROUND WALL BRACKET

091-BA4000

This bracket is designed to attach 2 inside panels at variable angles. You set the desired angle to form a round inside wall.

45° BRACKET

091-AT0045

This bracket is designed to attach 2 outside fillers at a 45° angle.

To be used with our inside 4" x 4" 45° corner or our swing corners.

0.60 lb.



0.70 lb.



22° BRACKET

091-AT0022

This bracket is designed to attach 2 outside fillers at a 22° angle. It can be used with our swing corners.

Options: 15° and 30°

ACCESSORIES

90° BRACKET

091-AT0090

This 90° bracket is built to replace standard neutral corners. It can be used on any panel size. A set of clips can replace many sizes of standard corners.



1.22 lb.

TIME SAVERS

TOOLS

WINCH AND STRAP

095-TR0000 (winch)

398-000003 (Strap)

This winch is used to straighten walls and hold them firmly in place. It attaches to a bolt and comes with a 30' strap.



7.2 lb.

FLAT TIES 8" OR 10"

8" 399-FT0008

10" 399-FT0010

Provides support through horizontal joints between 1 1/8" plywood forms when used with Flat Ties Wedges. Standard 8" and 10" sizes available in 100 pieces per box. Other sizes are special order.



42 lb. per box (8")
44 lb. per box (10")

TOOLS

TOOLS

FORM CLEATS 8" OR 10"

399-FC0008

8"

399-FC0010

10"

Form cleats are used to hold the top of 2 plywood forms. Standard 8" and 10" sizes available in 100 pieces per box.



45 lb. per box (8")
49 lb. per box (10")

TOOLS

TOOLS

FLAT TIE WEDGE

399-FTW000

Used to secure Flat Tie to 1 1/8" plywood forms. Remove when stripping and save for reusing.

50 pieces per box.



34 lb. per box

STACKING PLATE

091-PLE000

Same purpose as the flat tie wedge. To be used with our regular tie.

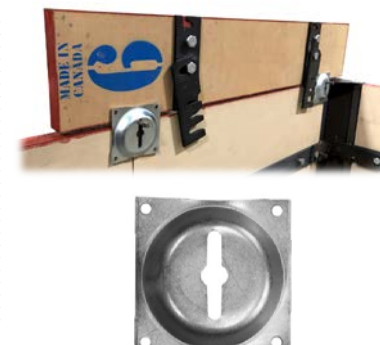

0.32 lb.

ACCESSORIES

TIME SAVERS

SWING CORNER LOCK

091-BA3044

This lock fixes the swing corner at the desired angle. With this lock in place, you'll never have to worry about your swing corners moving when you are pouring.

Options: 6" x 6"
8" x 8"



1.34 lb.

TIME SAVERS

MULTI ANGLE LOCK

091-BA2000

This lock is designed to attach 2 outside panels that are not at a 90° angle.



0.9 lb.

FOOTING BRACKETS

ADJUSTABLE FOOTING BRACKET (1X1 TUBE)

095-CFT00A

This bracket is designed to hold footing planks firmly in place at the desired width. Extendable from 20 to 42".



5.6 lb.

FOOTING BRACKETS

FOOTING BRACKET (2X4 PLANK)

095-CFA000

This footing bracket can be adjusted to different widths using 2" x 4" lumber. This is used to support and retain the 2" x 10" lumber during the casting of the footing. Sold individually. Wooden pieces not included.



5 lb.

FOOTING BRACKETS

FOOTING BRACKET (1X1 TUBE)

095-CFT0XX

This bracket is designed to hold footing planks firmly in place.

Option : Available with stoppers and in different length .



5.4 lb. (24")

6.1 lb. (27")

FOOTING BRACKETS

FOOTING BRACKET

095-CFPOXX

This bracket is designed to hold footing planks firmly in place.

Option : Available with stoppers and in different length .



4.9 lb. (24")

5.5 lb. (27")

ACCESSORIES

WALL ALIGNER WITH SCREW FOR 2X4

091-AL0024

Attached to a bolt and with a 2"x4" inserted horizontally, this product is designed to keep formwork straight.



2.5 lb.

TOOLS

TOOLS

WALL ALIGNER WITH WEDGE

091-ALT024

Attached to a bolt and with a 2"x4" inserted horizontally, this product is designed to keep formwork straight.



1.88 lb.

WALL ALIGNER WITH SCREW FOR 4X8

091-AL0048

The aligner is attached to the bolt. To be used with 4x4 lumber.



4.9 lb.

TOOLS

TOOLS

DOUBLE STRONGBACK WALER WITH WEDGE

091-SDD024

The aligner is attached to the bolt. To be used with 2x4 lumber..



2.1 lb.

STRONGBACK WALER WITH WEDGE

091-SD0024

Attached to a bolt and with a 2"x4" inserted vertically, this strongback waler is designed to keep formwork securely in place when stacking.



1.5 lb.

TOOLS

TOOLS

STRONGBACK WALER WITH SCREW

091-SDV024

Attached to a bolt and with a 2"x4" inserted vertically, this strongback waler is designed to keep formwork securely in place when stacking.



2.9 lb.

ACCESSORIES

REINFORCED TOP WALER FOR 2X4

091-RER024

This waler is used to correct and secure the alignment at the top of the formwork.

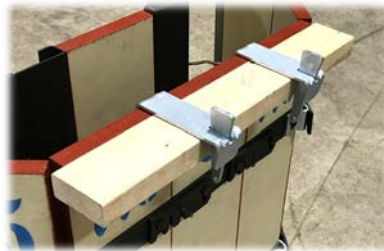

1.2 lb.



TOOLS

TOOLS

ALIGNMENT BRACKET

091-AT0004

This bracket is designed to attach a string quickly.



1 lb.



"H" BRACKET

091-HP0000

Designed for safely stacking panels to build a higher wall.



0.8 lb.



TOOLS

TOOLS

"H" BRACKET TO ADD 2X10

091-HM0210

Designed for safely stacking lumber on top of panels to build a higher wall while preserving wall thickness.



0.8 lb.



SCAFFOLDING BRACKET ADAPTOR FOR 2X2 CORNERS

091-AD0022

This adaptor attaches to a 2"x2" corner and is designed to support a scaffolding bracket. Also available for 4"x4" corners.

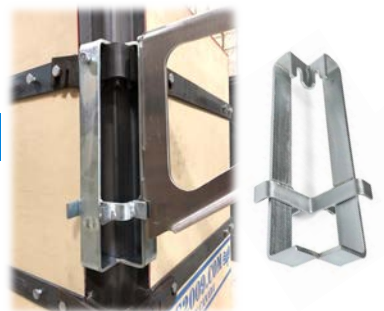

4.4 lb.



3.1 lb.

SCAFFOLDING BRACKET ADAPTOR FOR NEUTRAL CORNERS

091-AD0011

This adaptor attaches to a neutral corner and is designed to support a scaffolding bracket.

ACCESSORIES

SH FORM STACKER

091-BD1000

This bracket is designed for safely stacking panels to create a higher wall.



1.4 lb.

TOOLS



TOOLS



16 lb.

STACKING ANGLE BAR

091-FAD004

4 slots

091-FAD008 (reversible)

8 slots

This tool is used to stack panels. It is attached to the bolts on the panel. Similar use as a strongback waler.

Option: Available in different lengths and punching spacing

2' 2 BARS PANEL WITH TABS

047-200XS

This 2' panel is made for stacking. The bottom bar with tabs overlaps the top of the bottom panel.



TOOLS

TOOLS



10 lb.

TURNBUCKLE

395-TP0000

This accessory is designed for bracing.



PANEL PLUG

531-BT0000

This accessory is designed to avoid having a concrete knot. It provides a nicer finish wall.

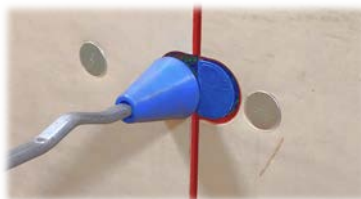

0.02 lb.

TOOLS

TOOLS



48 lb.

BOOM HOOK

091-CR0001

This device is designed to assist in handling form cages.

ACCESSORIES

MANUAL WIRE TWISTER

395-TB0002

This tool is used for rebar twist ties.



TOOLS

TOOLS

WIRE TWISTER

395-TB0001

This tool is used for rebar twist ties.



TWIST TIES

399-BV0008

These strong, flexible ties are ideal for attaching rebar.

Available in 6" and 8".



TOOLS

HARDWARE

PERFORATED STRAPPING

399-MEP000

300'

399-MEP001

110 lb.

Perforated strapping is used for unusual jobs where extra bracing is required.



12 lb. (300')

PERFORATED FOOTING STAKE

395-PI00XX

These stakes are used to hold footing planks in place. Available in 18", 24" and 36".



19 lb. (18")

HARDWARE

HARDWARE



800/box 800/box 3000/box

PANEL HARDWARE

635-SL0000 (SLEEVE)

635-B00000 (BOLT)

635-VI0625 (SCREW)

CORNER HARDWARE

675-B00000 (BOLT)

675-EC0004 (NUT)



ACCESSORIES

TOOLS

TRIPLE BREAK-OFF TOOL

091-CAT103

This tool is used to easily and quickly break off ties.
Can be used to screw and unscrew nuts on panels.



1.6 lb.

TOOLS

STRIPPING BEAM KIT

091-PDK000

Allows quick stripping of several panels at the same time. Stripping pliers and beam sold separately if needed. The chains come with the beam.

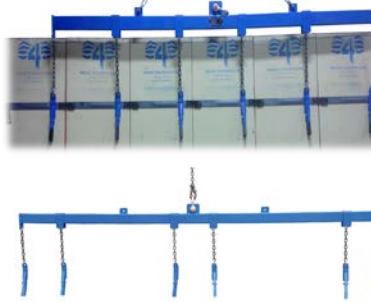

136 lb. (complete kit) 2.94 lb. (plier)

TOOLS

FORM AND CORNER STRIPPER

395-0D0001

This tool helps strip off corners and forms more easily.



8.36 lb.

TOOLS

LIGHT FORM STRIPPER

395-0D000A

This tool helps strip off forms and corners more easily.



2.56 lb.

TOOLS

HALF-CLIP

091-AC0002

The half-clip is used when forming against an existing wall or footing steps. The half-clip will hold the tie firmly in its notch.



TOOLS

CORNER CLIP

091-AC0001

Corner clips hold panels and corners that don't have latches firmly together.

Multifunctional



ACCESSORIES

6" LATCH

871-CR0060

The 6" latch is designed to attach a tie to the adjacent panel.



1 lb.

REPLACEMENT PARTS



0.5 lb.

INSIDE 2" AND 4"

871-CR0024

Attached to a 2" x 2" or 4" x 4" corner, this latch secures the tie and the adjacent panel.

REPLACEMENT PARTS

REPLACEMENT PARTS

1" LATCH WITH TIE SLOT

871-CR0010

This latch attaches a neutral outside corner to the adjacent panel.



0.3 lb.

HARDWARE



1 lb.

WELDED REVERSIBLE OFFSET LATCH

091-CRR000

Hold two panels together when the bars don't line up. Can be used on both sides of a panel. You simply attach it to the tie and bolt, then nail it in place.

HARDWARE

HARDWARE

BENT REVERSIBLE OFFSET LATCH

091-CRR001

Hold two panels together when the bars don't line up. Can be used on both sides of a panel. You simply attach it to the tie and bolt, then nail it in place.

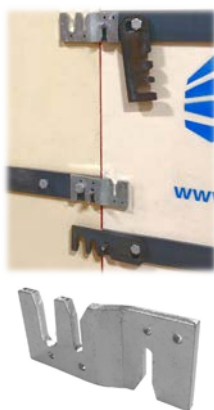

0.5 lb.



0.7 lb.

OFFSET LATCH

091-CR0000

Hold two panels together when the bars don't line up. Can be used on both sides of a panel. You simply attach it to the tie and bolt, then nail it in place.

ACCESSORIES

CONCRETE BUCKET

ALUMINUM CONCRETE BUCKET

394-BEXXXX

The aluminum concrete bucket is used to pour concrete into the formwork with a crane. Different capacities available.

Option : 1/2 or 3/4 yard 1/2 or 3/4 39" OD



220 lb. (1/2 yard)

CONCRETE CHUTE



40 lb. (12')

PVC CONCRETE CHUTE

094-DAPXXO

Designed to pour concrete into the formwork. Available in 12', 14' and 16'.

TOOLS

TOOLS

CONCRETE SPREADER

395-SP00XX

The concrete spreader is used to spread concrete and create a smooth finish on footings and flatwork. Available in 24", 30" and 36".



5.3 lb. (24")



4 lb.

FOOTING KEY TOOL

395-SP0000

This tool is used to make a key way in the footing.

Dimensions : 55" x 12.5"

TOOLS

HARDWARE

MAGNESIUM TROWEL

395-TR0016

This tool is used to produce a smooth finish on top of the formwork.



1.2 lb.



ANCHOR BOLTS

399-BA0008

Designed to anchor the building wall to the foundation. (1/2" x 8")

Option : Available in different sizes

OIL SPRAYER AND PARTS

RELIEF VALVE

536-00012

This part adjusts the oil pressure in the oil sprayer.



HOSE REEL

536-00047

Capacity of 150'



PUMP

536-00001

This part pumps the oil.



SWIVEL

536-00042



100' HOSE

536-00007



TANK FILTER

536-00002

Filter located inside the tank.



HEAVY DUTY GUN

536-00005



COMPLETE DOUBLE NOZZLE

096-D0000

Allows wider projection.



EXTENSION

096-RA0018 (18")

096-RA0036 (36")



OIL SPRAYER

096-HU3602

096-HU0000

20 gallon oil tank
5.5 hp Honda GX160 motor
1.8 gal, 1800 rpm pump
3/8" x 100', 2 ply hose



OIL SPRAYER AND PARTS

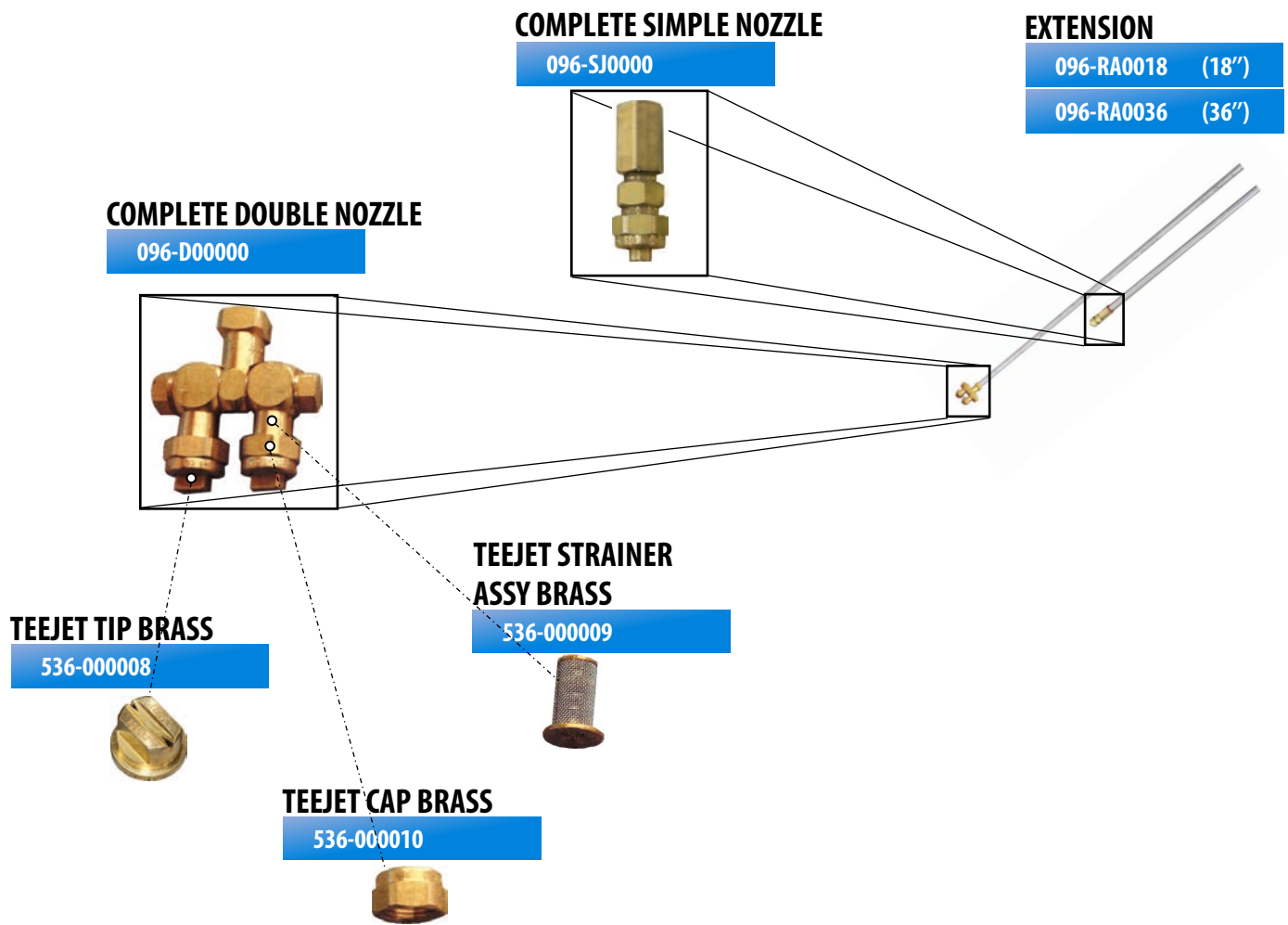

RELEASING AGENT

396-HUXX00

Summer and winter grade mineral oil, as well as all seasons grade biodegradable oil are available.

44 US gallons

CANADIAN PARTNERS



AMERICAN PARTNERS



Leominster, MASSACHUSETTS



Midwest, from Nebraska to Ohio



*Chatterton Construction Supply, LLC
Salt Lake City, UTAH*



Wildwood, MISSOURI



CONCRETE WORKS
Brookfield, CONNECTICUT



NEW YORK

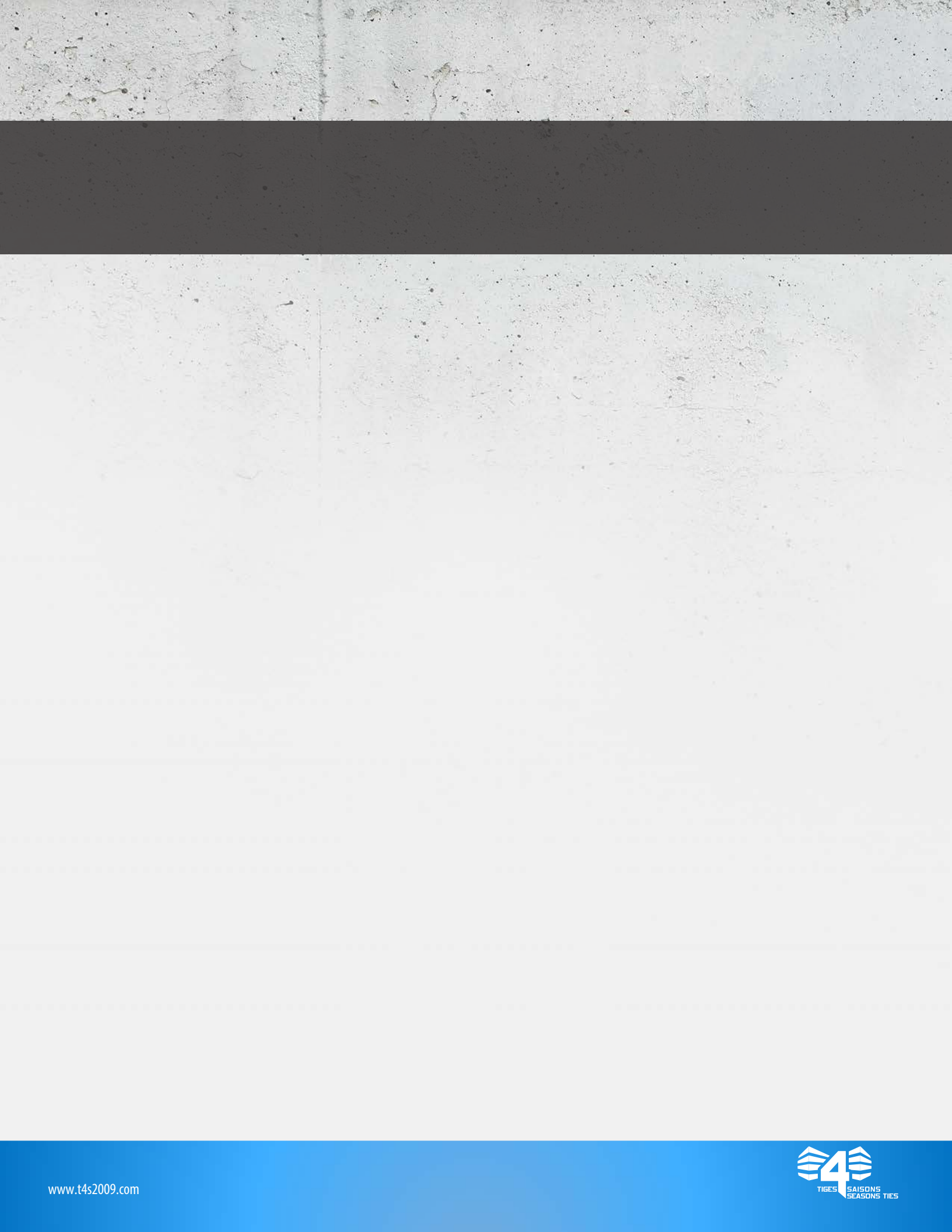

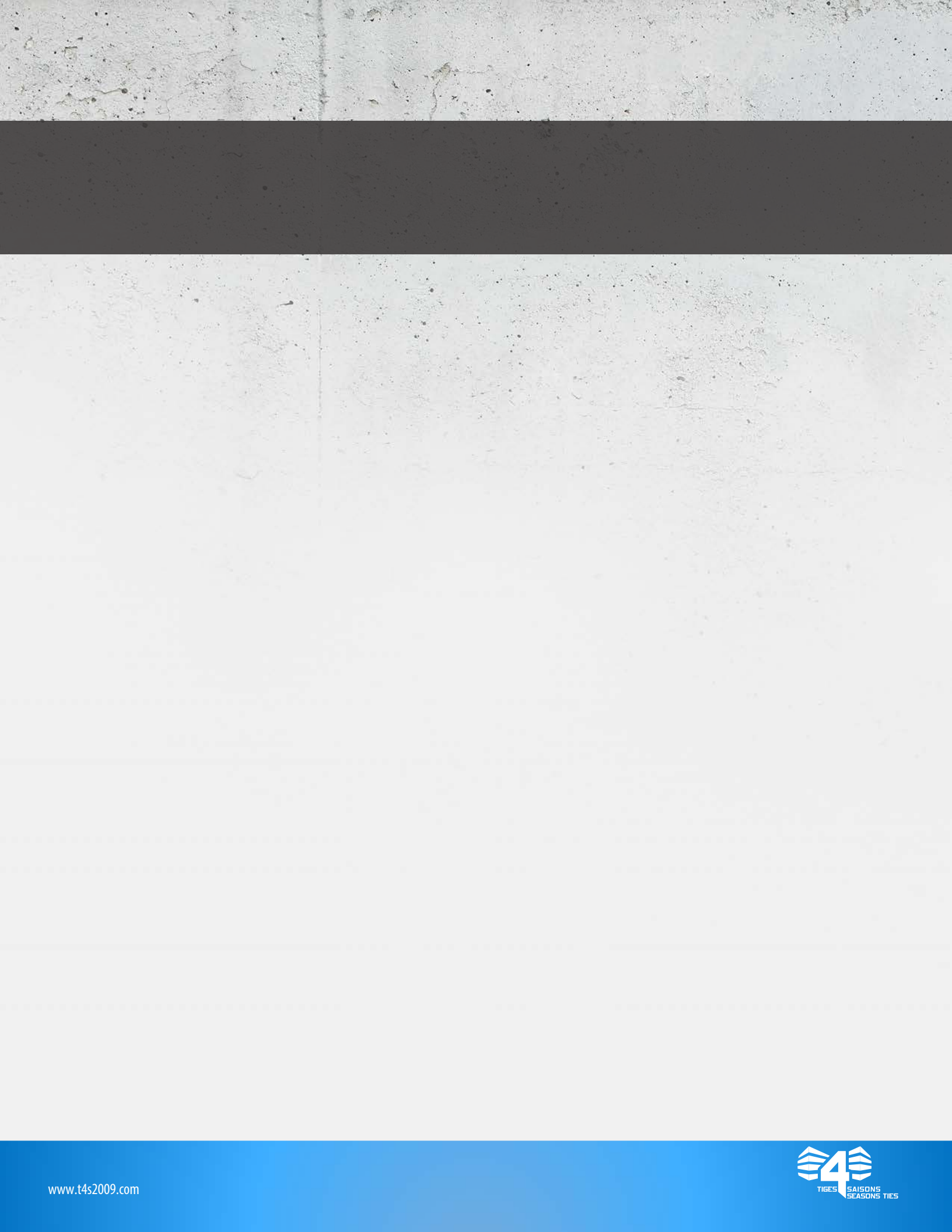



TIGES SAISONS 2009
SEASONS TIES